

T5 Processor Card

Configuration & Service Manual



Information contained in this document is subject to change without notice and Transponder Technologies does not guaranty that the content is free of typographical error. No part of this document may be reproduced or transmitted in any form or by any means without the express written permission of Transponder Technologies.

Original Author	Document Information	
Name: Mark Linsenmeier	File Name:D89169-4 Manual.doc	Pages: 34
	Document Number: D89169	Version: 4

APPROVALS

Title or Position	Name	Signature	Date
Operations Manager	Mark Bulmer		

CHANGE HISTORY

Revision	Date	Section	Change Details
1	9-Feb-05	All	First release
2	11-Aug-06	4.2	Added description of LPG mode totals
		5.2	Added additional configuration parameters - Delivery Limit - Pass code 1 to 3
		5.2.10	Added gallons mode and LPG mode with density probe cfg b values.
		5.2.9	Added extra cfg a options
3	28-Sep-06	5.2.10	Added monetary amount from litres display option to cfg b options.
		5.2.9	Added notes regarding editing parameters via preset keypad.
4	16-Nov-06	All	Convert to new numbering scheme

TABLE OF CONTENTS

1.	INTRODUCTION -----	5
1.1	BASIC DESCRIPTION -----	5
2.	WARNINGS -----	5
2.1	SAFETY PRECAUTIONS -----	5
2.2	STATIC ELECTRICITY PRECAUTIONS -----	5
3.	COMPONENT LOCATIONS AND FUNCTIONS -----	6
3.1	DIAGNOSTIC LED FUNCTIONS -----	7
3.2	SWITCH FUNCTIONS -----	7
3.3	CONNECTORS -----	8
3.3.1	<i>J1 – Magnetic Stripe Card Reader 1</i> -----	8
3.3.2	<i>J2 – Magnetic Stripe Card Reader 2</i> -----	8
3.3.3	<i>J3 – iButton Reader 1</i> -----	9
3.3.4	<i>J4 – iButton Reader 2</i> -----	9
3.3.5	<i>J5 – TBus Port (Power Rail Nr. 0)</i> -----	10
3.3.6	<i>J6 – TBus Port (Power Rail Nr. 1)</i> -----	10
3.3.7	<i>J7 – TBus Port (Power Rail Nr. 2)</i> -----	11
3.3.8	<i>J8 – Nozzle Switches</i> -----	12
3.3.9	<i>J9 – Power Input</i> -----	13
3.3.10	<i>J10 – Email FCN Interface Card Connector</i> -----	14
3.3.11	<i>J11 – External Buzzer</i> -----	14
3.3.12	<i>J12 – Electromechanical Totalisors</i> -----	15
3.3.13	<i>J13 – Air Detect / Sump Switches</i> -----	15
3.3.14	<i>J14 to J19 - Pulsers</i> -----	16
3.3.15	<i>J20 – External Parameter Switch</i> -----	16
3.3.16	<i>J21 – Motor / Solenoid Valve Control</i> -----	17
3.3.17	<i>J22 – Microcontroller Programming</i> -----	17
3.4	FIELD REPLACEABLE PARTS -----	18
4.	OPERATING MODES -----	19
4.1	STANDARD MODE -----	19
4.2	DISPLAY ELECTRONIC TOTALS MODE -----	19
4.3	CAS MODE -----	19
4.4	CRIP MODE -----	19
4.5	ITOTES MODE -----	21
5.	SYSTEM SETUP -----	22
5.1	GENERAL PROCEDURE -----	22
5.2	K-FACTOR SWITCH -----	23
5.2.1	<i>K-Factor</i> -----	23
5.2.2	<i>Preset cut-off</i> -----	24
5.2.3	<i>Start flow timeout</i> -----	24
5.2.4	<i>End flow timeout</i> -----	24
5.2.5	<i>Minimum flow rate</i> -----	24
5.2.6	<i>Solenoid delay</i> -----	24
5.2.7	<i>Price resolution</i> -----	24
5.2.8	<i>Configuration b</i> -----	26
5.2.9	<i>Configuration a</i> -----	27
5.3	PARAMETER SWITCH -----	28
5.3.1	<i>Software version</i> -----	28
5.3.2	<i>Unit price</i> -----	28
5.3.3	<i>Cause of delivery end</i> -----	28

- 5.3.4 *Pump Number*-----29
- 5.3.5 *LPG Density*-----29
- 5.3.6 *LPG Temperature* -----29
- 5.3.7 *Configuration p*-----30
- 5.3.8 *Identifier enable* -----30
- 5.3.9 *Access Code*-----30
- 5.4 METER CALIBRATION -----31
- 6. DIAGNOSTICS -----32**
- 6.1 ERROR MESSAGES-----32
 - 6.1.1 *Fatal Error Codes*-----32
 - 6.1.2 *Non-Fatal Error Codes*-----33
 - 6.1.3 *Passive State Indicators* -----33
- 6.2 FAULT FINDING -----34

1. Introduction

This manual provides details for configuring and servicing the T5 Processor Card as part of a fuel dispensing system. This document is current for the following finished assembly part number:

TT Part No.	TT Name
080563-3	PCBAssy T5 Processor Card

Configuration options are correct for firmware version TRA01272.

Please read this entire manual before attempting any service work on this device.

1.1 Basic Description

The T5 Processor Card is a microprocessor based device that is the central device in all T5 Electronics based dispensing system. It is singularly capable of supporting all of the devices necessary to implement a full 6 hose multiple product style pump or dispenser. Control of peripheral devices is done either via direct connection to the card or connection via the proprietary TBus internal pump network. Together with approved peripherals, the T5 processor Card forms systems that are intrinsically safe and can be used in a zone 1 hazardous area. For further details of the approved configurations for the T5 Processor Card and systems please contact Transponder Technologies.

2. WARNINGS

2.1 Safety Precautions

The T5 Processor Card, and its associated circuits and wiring, is certified electrical equipment approved for use in a hazardous area (Class 1 Zone 1, Group IIA T3). Only parts identical to those covered by the certification may be used where the integrity of the intrinsic safety may be affected. All circuit boards are only to be repaired by an approved service organisation.

2.2 Static Electricity Precautions

Electronic components used are sensitive to static. Please take anti-static precautions.

All circuit boards must be carried and transported in static-shielded bags. An anti-static wrist strap should be worn and connected correctly when working on any electronic equipment. If an anti-static wrist strap is unavailable, or in an emergency, regular discharge of built up static electricity must be carried out by touching an earthed metallic part. **DO NOT DO THIS IN A HAZARDOUS AREA.** This is not a recommended alternative to wearing an anti-static wrist strap.

Note: Transponder Technologies reserves the right to refuse to accept any circuit boards returned, if proper anti-static precautions have not been taken.

3. Component Locations and Functions

The image below shows the locations of various components on the Card. Subsequent sections will refer to this image and provide detail on the purpose of these components.

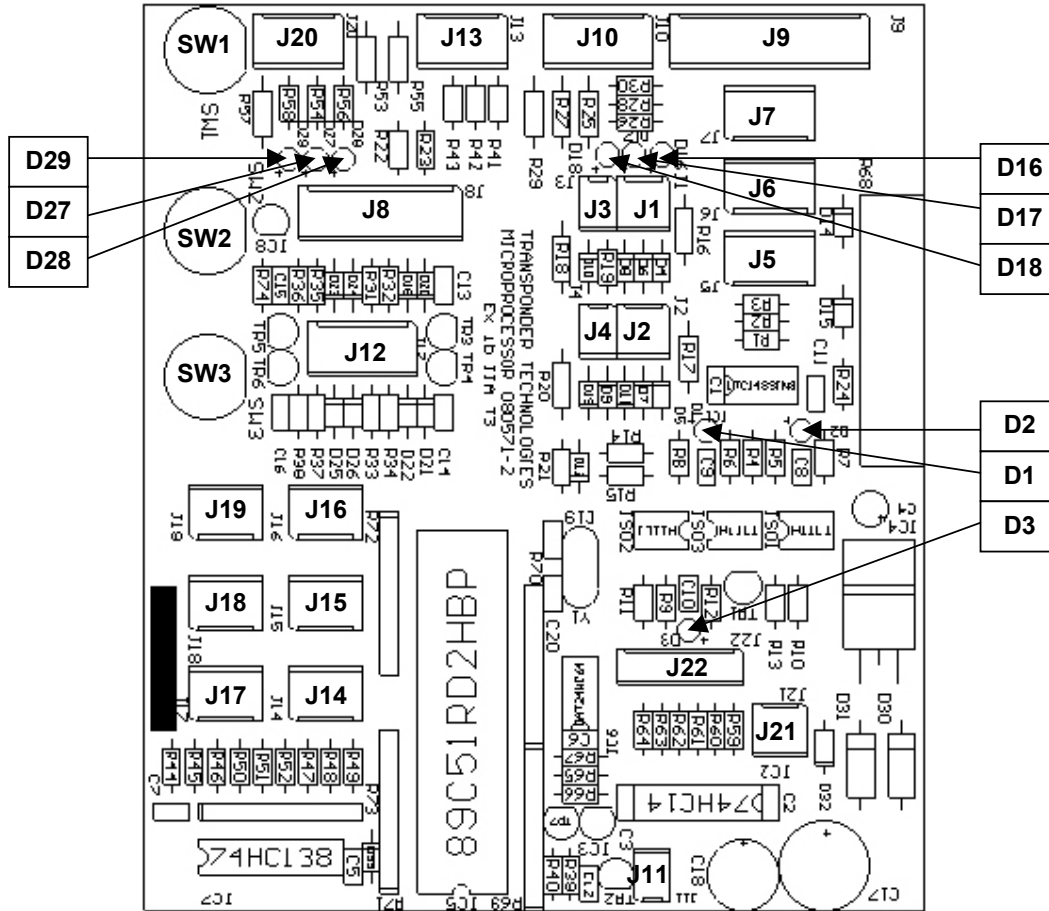

Figure 1 – Component Locations

3.1 Diagnostic LED functions

Diagnostic LED	Colour	Function
D1	Yellow	TBus Tx Enable LED. Flashes when Processor is sending data over the TBus network.
D2	Red	TBus Transmit LED. Flashes when Processor is sending data over the TBus network.
D3	Green	TBus Receive LED. Flashes when Processor is receiving data from the TBus network.
D16	Green	FCN Receive LED. Flashes when Processor is receiving data over the Forecourt Network.
D17	Red	FCN Transmit LED. Flashes when Processor is transmitting data over the Forecourt Network.
D18	Yellow	FCN Tx Enable LED. Flashes when Processor is transmitting data over the Forecourt Network.
D27	Red	Diagnostic LED 1. Turns on while switch SW1 is depressed.
D28	Red	Diagnostic LED 2. Flashes quickly when any nozzle is lifted. Flashes slowly when all nozzles are stowed. Turns on while SW2 is depressed.
D29	Red	Diagnostic LED 3. Turns on while switch SW3 is depressed.

3.2 Switch functions

Switch Designator	Function
SW1	Parameter Switch. See section 5.3 for details.
SW2	K-Factor Switch. See section 5.2 for details.
SW3	Advance Parameter Switch. See section 5.1 for details.

3.3 Connectors

This section describes the function of each connector on the Card and includes diagrams showing the pin-outs. Note that the orientation of the connectors in the pin-out diagrams matches the orientation of the connectors as shown in Figure 1 – Component Locations.

3.3.1 J1 – Magnetic Stripe Card Reader 1

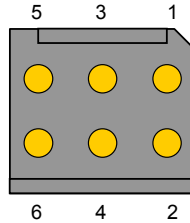

Plug: Interkontakt CSD-06DS-

Pin No.	Function	Direction
1	+5VDC power supply to card reader	Output
2	Card data	Input
3	Data clock	Input
4	Card present	Input
5	Ground	
6	Ground for cable screen drain wire	

3.3.2 J2 – Magnetic Stripe Card Reader 2

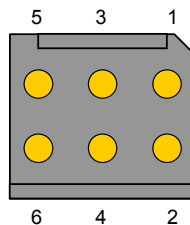

Plug: Interkontakt CSD-06DS-

Pin No.	Function	Direction
1	+5VDC power supply to card reader	Output
2	Card data	Input
3	Data clock	Input
4	Card present	Input
5	Ground	
6	Ground for cable screen drain wire	

3.3.3 J3 – iButton Reader 1

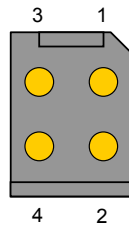

Plug: Interkontakt CSD-04DS-

Pin No.	Function	Direction
1	iButton reader data line (centre contact)	Both
2	iButton reader ground (outer contact)	
3	Spare ground	
4	Ground for cable screen drain wire	

3.3.4 J4 – iButton Reader 2

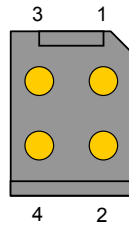

Plug: Interkontakt CSD-04DS-

Pin No.	Function	Direction
1	iButton reader data line (centre contact)	Both
2	iButton reader ground (outer contact)	
3	Spare ground	
4	Ground for cable screen drain wire	

3.3.5 J5 – TBus Port (Power Rail Nr. 0)

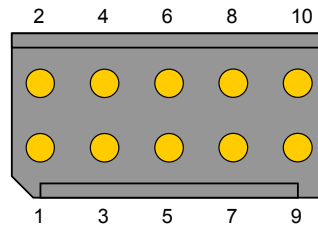

Plug: Interkontakt CSD-10DS-

Pin No.	Function	Direction
1	TBus RS485 Signal A	Both
2	TBus RS485 Signal B	Both
3	TBus Communications Ground	
4	TBus Communications +5VDC	Output
5	Not connected	
6	Not connected	
7	Ground	
8	Ground	
9	+10VDC Power Rail Nr. 0	Output
10	Ground for cable screen drain wire	

3.3.6 J6 – TBus Port (Power Rail Nr. 1)

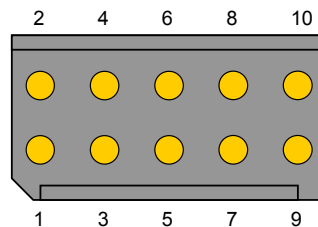

Plug: Interkontakt CSD-10DS-

Pin No.	Function	Direction
1	TBus RS485 Signal A	Both
2	TBus RS485 Signal B	Both
3	TBus Communications Ground	
4	TBus Communications +5VDC	Output
5	Not connected	
6	Not connected	
7	Ground	
8	Ground	
9	+10VDC Power Rail Nr. 1	Output
10	Ground for cable screen drain wire	

3.3.7 J7 – TBus Port (Power Rail Nr. 2)

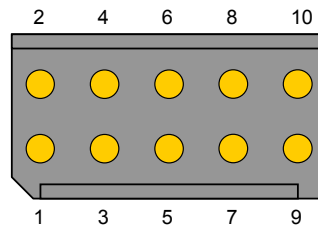

Plug: Interkontakt CSD-10DS-

Pin No.	Function	Direction
1	TBus RS485 Signal A	Both
2	TBus RS485 Signal B	Both
3	TBus Communications Ground	
4	TBus Communications +5VDC	Output
5	Not connected	
6	Not connected	
7	Ground	
8	Ground	
9	+10VDC Power Rail Nr. 2	Output
10	Ground for cable screen drain wire	

3.3.8 J8 – Nozzle Switches

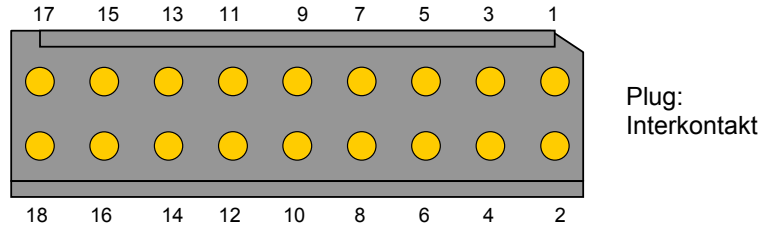

Pin No.	Function	Direction
1	Nozzle Switch 0	Input
2	Nozzle Switch 1	Input
3	Ground for switch 0	
4	Ground for switch 1	
5	Ground for cable screen drain wire from switch 0	
6	Ground for cable screen drain wire from switch 1	
7	Nozzle Switch 2	Input
8	Nozzle Switch 3	Input
9	Ground for switch 2	
10	Ground for switch 3	
11	Ground for cable screen drain wire from switch 2	
12	Ground for cable screen drain wire from switch 3	
13	Nozzle Switch 4	Input
14	Nozzle Switch 5	Input
15	Ground for switch 4	
16	Ground for switch 5	
17	Ground for cable screen drain wire from switch 4	
18	Ground for cable screen drain wire from switch 5	

NOTE: Nozzle switch inputs are shorted to ground when the nozzle is lifted.

3.3.9 J9 – Power Input

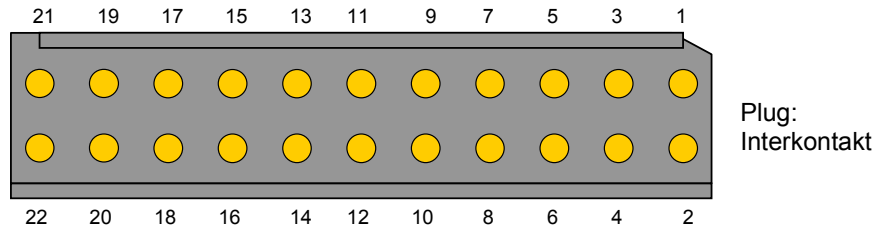

Pin No.	Function	Direction
1	Ground	
2	+10VDC Power Rail Nr. 0	Input
3	Power Fail Signal	Input
4	Ground	
5	Ground	
6	+10VDC Power Rail Nr. 1	Input
7	Ground for cable screen drain wire	
8	Ground	
9	Ground	
10	+10VDC Power Rail Nr. 2	Input
11	Not connected	
12	Not connected	
13	TBus Communications Ground	
14	TBus Communications +5VDC	Input
15	TBus RS485 Signal B	Both
16	TBus RS485 Signal A	Both
17	Not connected	
18	Not connected	
19	Forecourt Pump Communications Receive	Input
20	Forecourt Pump Communications +5VDC	Output
21	Forecourt Pump Communications Transmit	Output
22	Ground	

3.3.10 J10 – Email FCN Interface Card Connector

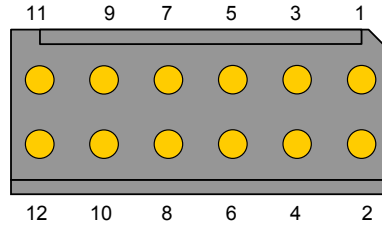

Plug: Interkontakt CSD-12DS-

Pin No.	Function	Direction
1	+10VDC Power Rail Nr. 0	Output
2	Ground	
3	Ground	
4	Ground	
5	Not connected	
6	Not connected	
7	+5VDC	Output
8	Receive Data	Input
9	Ground	
10	Transmit Data	Output
11	Ground for cable screen drain wire	
12	Transmit Enable	Output

3.3.11 J11 – External Buzzer

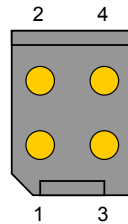

Plug: Interkontakt CSD-04DS-

Pin No.	Function	Direction
1	+5VDC Buzzer Signal	Output
2	Ground	
3	Ground	
4	Ground for cable screen drain wire	

3.3.12 J12 – Electromechanical Totalisers

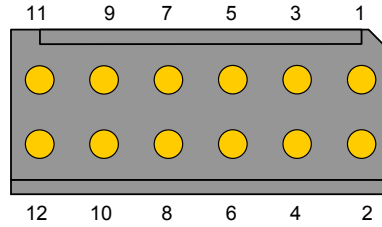

Plug: Interkontakt CSD-12DS-

Pin No.	Function	Direction
1	+5VDC Signal for Tote 0	Output
2	+5VDC Signal for Tote 1	Output
3	Ground for Tote 0	
4	Ground for Tote 1	
5	Ground for cable screen drain wire from Tote 0	
6	Ground for cable screen drain wire from Tote 1	
7	+5VDC Signal for Tote 2	Output
8	+5VDC Signal for Tote 3	Output
9	Ground for Tote 2	
10	Ground for Tote 3	
11	Ground for cable screen drain wire from Tote 2	
12	Ground for cable screen drain wire from Tote 3	

3.3.13 J13 – Air Detect / Sump Switches

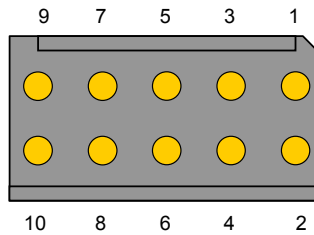

Plug: Interkontakt CSD-10DS-

Pin No.	Function	Direction
1	Air Detect Switch 0	Input
2	Air Detect Switch 1	Input
3	Ground for switch 0	
4	Ground for switch 1	
5	Ground for cable screen drain wire from switch 0	
6	Ground for cable screen drain wire from switch 1	
7	Not connected	
8	Ground for sump switch	
9	“Sump full” switch input.	Input
10	Ground for cable screen drain wire from sump switch	

3.3.14 J14 to J19 - Pulsers

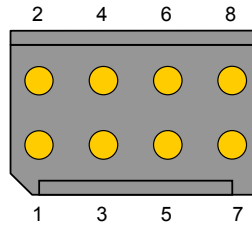

Plug: Interkontakt CSD-08DS-

Pin No.	Function	Direction
1	Channel 0	Input
2	+5VDC	Output
3	Channel 1	Input
4	Not connected	
5	Channel 2	Input
6	Ground	
7	Pulser Enable (strobe)	Output
8	Ground for cable screen drain wire	

3.3.15 J20 – External Parameter Switch

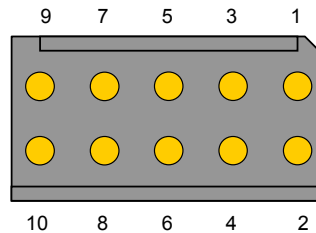

Plug: Interkontakt CSD-10DS-

Pin No.	Function	Direction
1	Parameter Switch Input (SW0)	Input
2	Not connected	
3	Ground for switch input	
4	Not connected	
5	Ground for cable screen drain wire from switch	
6	Not connected	
7	Not connected	
8	Not connected	
9	Not connected	
10	Not connected	

NOTE: External parameter switch must be a normally-open type wired across pins 1 and 3.

3.3.16 J21 – Motor / Solenoid Valve Control

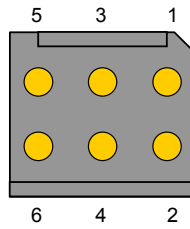

Plug: Interkontakt CSD-06DS-

Pin No.	Function	Direction
1	Side A Motor Activate Signal	Output
2	Side B Motor Activate Signal	Output
3	Side A Lo-flow Solenoid Valve Activate Signal	Output
4	Side B Lo-flow Solenoid Valve Activate Signal	Output
5	Side A Hi-flow Solenoid Valve Activate Signal	Output
6	Side B Hi-flow Solenoid Valve Activate Signal	Output

3.3.17 J22 – Microcontroller Programming

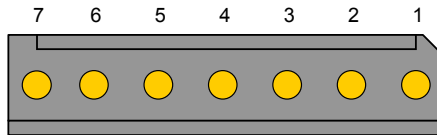

Plug:
Interkontakt

Pin No.	Function	Direction
1	+5VDC	Output
2	Reset (active low)	Input
3	Programming Power supply	Input
4	Programming Enable signal	Input
5	Transmit data	Output
6	Receive data	Input
7	Ground	

3.4 Field replaceable parts

K-Factor switch seal

After calibration, switch SW2 is fitted with a seal that prevents the switch from being depressed. This button seal, as shown in the picture below, is TT Part No. 078061.



Figure 2 – Button Seal

4. Operating Modes

The T5 Register Electronics can be configured to operate in several different modes. This section describes each mode of operation. For details on how to configure the system to operate in each mode, please see section 5.

4.1 Standard Mode

In Standard Mode, the system behaves as a normal pump/dispenser without any ID reading ability.

4.2 Display Electronic Totals Mode

This is a temporary mode of operation where the system displays the dollar and litre totals stored in non-volatile memory. To enter this mode, do the following:

1. Lift the nozzle from the holder,
2. Hold down the nozzle switch for at least three seconds,
3. Then tap the switch up and down five times or more in quick succession.

The dollar and litres totals for the selected hose will appear on the display for 10 seconds.

If the system is configured in LPG mode then the litre and dollar totals are displayed separately and sequentially with the 6 least significant digits displayed on the litre display panel and the 4 most significant digits in the price display panel.

4.3 CAS Mode

CAS stands for Card-Acceptor-Station. By adding a dot-matrix display, a numeric keypad, an optional receipt printer, and a magstripe card-reader or an iButton reader, the functionality of a DCA can be provided. When a customer presents an ID at the station he is prompted for a receipt, to enter a PIN, an odometer and other information, and to select a pump for authorisation. Subsequent transactions are stored in the forecourt controller for later processing.

The forecourt controller communicates with the CAS in the same way as it communicates with a pump. To configure the T5 as a CAS it should be set for a single hose, and for New Zealand standard protocol. The pump number setting identifies the device to the forecourt control system.

By configuring the T5 for multiple hose operation it can provide the combined functionality of a CAS and a register. Hence to configure as a dual register with CAS the T5 should be set for three hoses. The last hose allocated (in this case the third) is reserved for the CAS.

4.4 CRIP Mode

CRIP stands for Card-Reader-In-Pump. In this case the components associated with a CAS (keypad, card-reader, etc) are installed at each pump on the site. The authorisation procedure is

identical except that the customer is not prompted to select a pump since implicitly the pump to be authorised is the one at which the identifier has been presented. A T5 operating as a CRIP is always configured for a single hose.

4.5 iTotes Mode

By simply adding a magstripe cardreader or an iButton reader the T5 may be converted into a simple, low cost, unattended card management system. In this mode of operation the pump can only be authorised by presenting an identifier (a card or iButton).

Identifiers are encoded with an access code (to identify the system) and an ID number (to identify the customer/person).

The system accumulates non-resettable totals for up to 500 identifiers. There are several methods of accessing ID totals. These are:

- Configure for scrolling totes mode. In this mode of operation when electronic totals are displayed (using the procedure described in section 4.2) the system will also display totals for all IDs that are either valid, or have a non-zero total. Each total is displayed for 10 seconds during which the total is flashed alternately with the id number.
- Where iButtons are used a special type of iButton may be issued which, when presented at the system, collects all current ID totals. When this iButton is subsequently presented at a PC running a special software application these totals are uploaded and stored in a database. Reports may then be generated, which compare previously uploaded totals to show fuel consumption using a variety of criteria.

When an ID is presented the current id totals are displayed on the dollar and litre displays until the nozzle is lifted.

5. System Setup

All configuration parameters and modes of operation are set using the two configuration switches mounted on the Processor board (see section 3.2).

The K-Factor switch is normally used only when the system is initially configured or when the meters are recalibrated. It should be accessed only by authorised service personnel. After use the K-Factor switch must be sealed from operation in an approved manner.

The Parameter switch is for setting parameters that may be altered by service station personnel. This switch is not required to be sealed.

The Advance Parameter switch can be used to quickly advance to the required parameter. This switch is not required to be sealed when used in this manner.

5.1 General Procedure

The procedure for operating either switch is as follows:

1. Ensure that filling has stopped and that all nozzles are stowed.
2. Press and release the appropriate configuration switch in quick succession until the desired parameter name is displayed. Alternatively, once a configuration switch (SW1 or SW2) has been pressed, SW3 can be used to advance quickly to a parameter without having to cycle through each digit. The Price display will contain the name of the parameter and the Litres display will show an abbreviated name and the current value of the parameter.
3. Continue pressing and releasing the switch until the desired digit of the parameter is selected. The selected digit will be momentarily replaced by a '-' character when the switch is first pressed.
4. Hold down the configuration switch and the selected digit will increment through all legal values. When the digit has reached its maximum legal value, the next value it will change to will be its minimum legal value ie. The digit values 'roll' over.
5. When the value is as desired, release the configuration switch.
6. Repeat steps 3 to 5 for each digit that is required to be changed.
7. Repeat step 2 to select the next required parameter.
8. When no switch presses have been detected for 10 seconds, the display will revert back to showing the last fill amount and the system will adopt the new parameter values.

Note that where a system is configured for multiple hose operation and the parameter being set relates to one particular hose in the system, the parameter will only be shown in the display corresponding to the hose being configured. All the other displays are blanked. In the two tables following, parameters for which this applies will be marked _{HSP} (Hose Specific Parameter).

5.2 K-Factor Switch

The parameters that can be configured via the K-Factor switch are defined in the table below in the order that they can be accessed. Following the table, is further explanation of each parameter.

Parameter	Text shown on display	
	Price Display ¹	Litres Display
K-Factor _{HSP}	FActr	XX.XXXX
Preset cut-off	Pcut	t X.XX
Start flow timeout	S Flo	S XXX
End flow timeout ²	E Flo	E XXX
Minimum flow rate ³	L Flo	L XXX
Solenoid delay ²	Sd	d XX
Price resolution	<i>See description</i>	r X
Configuration b	cFg b	bXXXXXX
Configuration a	cFg A	AXXXXXX
Delivery Limit ²	tOP	XXXXXX
Pass code 1 ³	PASS1	XXXXXX
Pass code 2 ³	PASS2	XXXXXX
Pass code 3 ³	PASS3	XXXXXX

¹ Not available with 'litres only display' systems.

² Not available if in a LPG mode. See 'Configuration b' section 5.2.10.

³ Only available if in a LPG mode. See 'Configuration b' section 5.2.10.

5.2.1 K-Factor

The Calibration ('K') Factor is used to calibrate the meter(s). The procedure for calibrating a meter is described in section 5.4.

The range of this parameter is 00.0000 to 99.9999 inclusive.

5.2.2 Preset cut-off

The Preset cut-off parameter only applies during preset deliveries. It is the amount off litres prior to attaining the preset at which the dispenser will switch from full flow to low flow.

The range of this parameter is 0.00-9.99 litres inclusive. A setting of 0.00 will result in a cut-off margin of 0.32 litres. The default setting is 0.00.

5.2.3 Start flow timeout

The Start-flow timeout is the length of time that the dispenser will wait for flow to start after the nozzle has been lifted. If this time limit is exceeded then the delivery will finish and the nozzle must be stowed before another delivery can commence.

The range of this parameter is 000-999 seconds inclusive. A setting of 000 will result in a timeout of 4 minutes. The default setting is 000.

5.2.4 End flow timeout

The End-flow timeout applies once delivery flow has commenced. When flow has stopped, the system will wait this long before ending the delivery.

The range of this parameter is 000-254 seconds inclusive. A setting of 000 will result in a timeout of 4 minutes. The default setting is 000. This parameter is not available if in a LPG mode.

5.2.5 Minimum flow rate

The system will stop the delivery if three times during the delivery the flow rate drops below this value for at least 10 seconds. The display will also flash the 'no FLo' error message.

The range of this parameter is 000-999 litres/minute inclusive. The default setting is 000. This parameter is only available if in a LPG mode.

5.2.6 Solenoid delay

The Solenoid delay parameter is used in dispenser installations with a submersible pump. A non-zero value in this parameter delays the activation of the solenoid outputs after the motor output has been activated. This allows pressurisation of the pipes to the dispenser to occur and for leak detection apparatus to operate.

The range of this parameter is 00-99 seconds inclusive. Setting the parameter to 0 means the solenoid and motor outputs will be activated at the same time. This parameter is not available if in a LPG mode.

5.2.7 Price resolution

This parameter sets the number of decimal places for the Unit Price parameter. It can be set to 0, 1, 2 or 3. As the parameter is changed, the Unit Price (price per litre) display will show zeros with the decimal place in the appropriate location as will the Price display. The default value is 3.

5.2.8 Delivery Limit





Sets the maximum amount (dollars) or volume (litres) that may be dispensed. If set to zero then no limit applies.

5.2.9 Pass codes

These parameters define the pass codes that enable system configuration and data access via the preset keypad (if fitted). The three pass codes allow the operator access to the following functionality once entered correctly:

Pass code 1	Allows totals to be viewed
Pass code 2	Allows price setting, pump number setting and setting of configuration p values. It also enables the temperature and software version number to be viewed.
Pass code 3	Allows k-factor setting, setting configuration a & b values, start flow timeout, currency resolution, minimum flow rate and density. It also enables cause of delivery end and the k-factor

Notes regarding using the preset keypad to edit parameters:

- The  key is used to ‘scroll’ through the available parameters
- To clear/zero the parameter currently being displayed and to allow a new value to be entered the following key sequence needs to be performed:  →  → 

5.2.10 Configuration b

Each individual digit in this configuration parameter controls an aspect of the systems operation as shown in the chart below. The default for each digit is underlined. In some cases the default is defined by the delivered configuration of the T5 System so a default value will not be indicated.

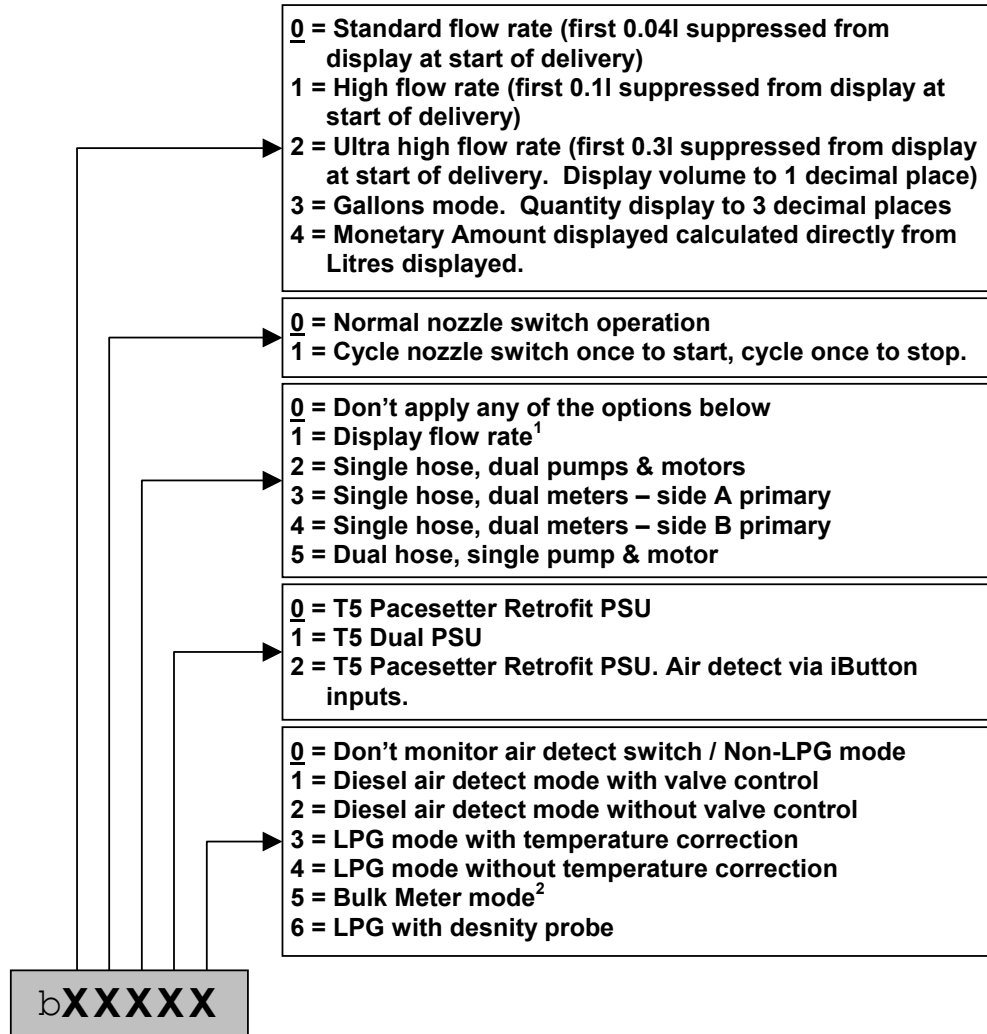

Figure 3 - Configuration b

NOTES:

1. “Display flow rate” option requires a system with a Litres-only Display card connected in addition to the primary display.
2. When “Bulk Meter mode” is enabled, the T5 will display volumes of greater than 10,000 litres with 1 decimal place instead of 2. The maximum single fill volume in Bulk Meter mode is 60,000 litres (instead of 10,000).

5.2.11 Configuration a

Each individual digit in this configuration parameter controls an aspect of the systems operation as shown in the chart below. The default for each digit is underlined. In some cases the default is defined by the delivered configuration of the T5 System so a default value will not be indicated.

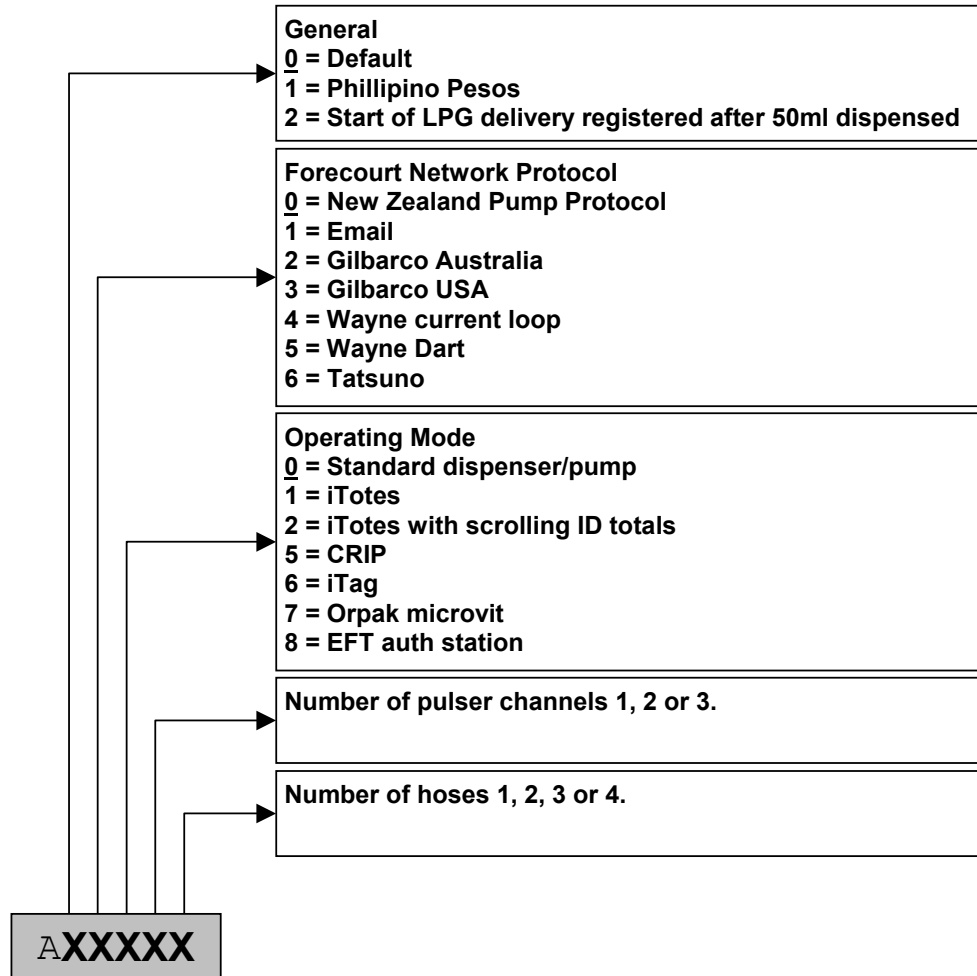

Figure 4 - Configuration a

5.3 Parameter Switch

The parameters that can be configured via the Parameter switch are defined in the table below in the order that they can be accessed. Following the table, is further explanation of each parameter.

Parameter	Text shown on display	
	Price Display ¹	Litres Display
Software version	Code	XXXXX
Unit price _{HSP}	Price	P XXX.X
Cause of delivery end _{HSP}	cdE	XXXXX
Pump number _{HSP}	Pu nu	n XX
LPG density ²	dEn	XXX.X
LPG temperature ²	tEP	XX.X
Configuration p	cFg P	P XXX
Identifier enable ³	id En	X XX
Access code ³	ACCESS	A XXXX

¹ Not available with 'litres only display' systems.

² Only available if in a LPG mode. See 'Configuration b' section 5.2.7.

³ Only available if iTote enabled. See 'Configuration a' section 5.2.11.

5.3.1 Software version

When the Parameter switch is first pressed the system will display the software version number alternating with a LCD segment test sequence.

5.3.2 Unit price

Sets the price per litre for a particular hose. The range is 000.0 to 999.9 cents/litre.

5.3.3 Cause of delivery end

This parameter shows why the last delivery ended as per the table below:

Text Displayed	Explanation
nd	A delivery has not yet occurred since the system was powered on.
HOSE	Nozzle stowed.

Fcc	Forecourt controller stopped the delivery.
S Flo	Start flow timer expired.
E Flo	End flow timer expired.
PrESet	Stopped at preset amount.
toP	Delivery quantities reached maximum amount able to be displayed.
Error	An error occurred during delivery. See section 6.1.
Air	The air detect switch closed during the delivery.
Pd	Pulser disconnected.
dEn	LPG density outside of range.
tEP	LPG temperature outside of range.

5.3.4 Pump Number

The Pump Number parameter identifies the pump when it is interfaced to a forecourt control system. Pump Numbers must be unique on a particular forecourt network channel.

5.3.5 LPG Density

The LPG Density parameter is the static density which is used, together with temperature, to calculate the dispensed volume. The allowable range is 500.0 to 600.0 kg/m³. If the parameter is set to a value outside this range then, when a delivery starts, the system will stop the delivery and display the 'dEn' error. This parameter is only available if in a LPG mode.

5.3.6 LPG Temperature

The LPG Temperature parameter sets the static temperature which is used, together with density, to calculate the dispensed volume. The range is -25.0 to 55.5 °C. If the parameter is set to a value outside this range then, when a delivery starts, the system will stop the delivery and display the 'tEP' error. This parameter is only available if in a LPG mode.

5.3.7 Configuration p

Each individual digit in this configuration parameter controls an aspect of the systems operation as shown in the chart below. The default for each digit is underlined. In some cases the default is defined by the delivered configuration of the T5 System so a default value will not be indicated.

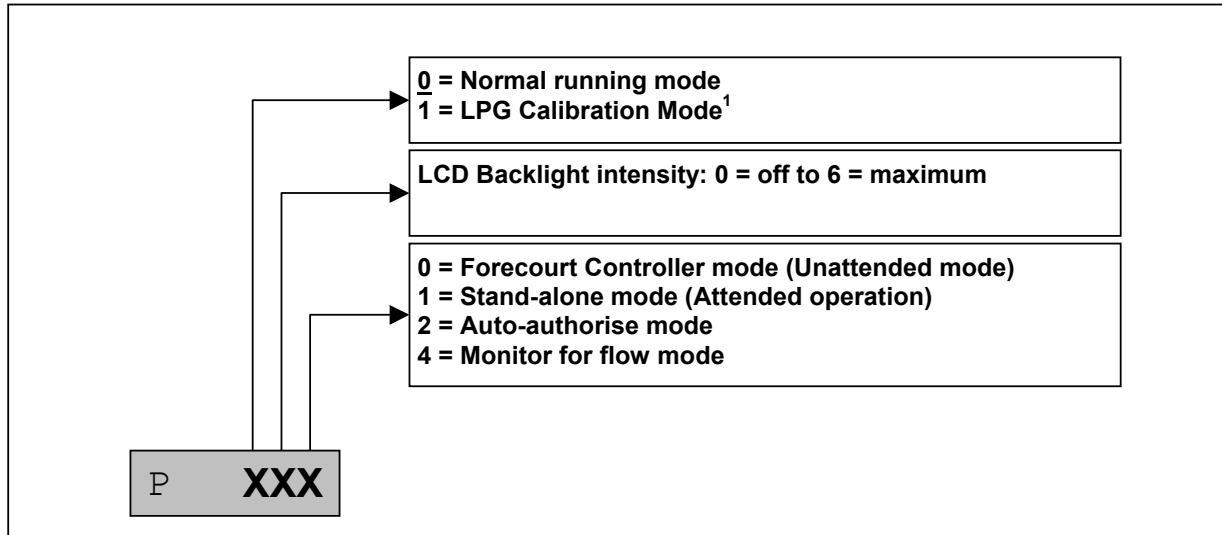

Figure 5 - Configuration p

NOTES:

1. When the system is in LPG Calibration Mode the Price display will show non-compensated litres and the Price per Litre display will show the temperature.

5.3.8 Identifier enable

This option only appears when the system is configured for iTotes mode. The identifier number appears in the right two digits of the litre display. The status of the identifier appears in the middle digit. A 'y' indicates that the identifier is valid. A 'n' indicates that it is invalid. When the status digit is selected it will toggle from 'y' to 'n' to 'y' while the switch is held.

5.3.9 Access Code

This option only appears when the system is configured for iTotes mode. The access code uniquely identifies the system so that identifiers issued for other systems will not be accepted. The access code should be set to match that encoded in the identifiers used.

5.4 Meter Calibration

The K-Factor is used to calibrate the meter. It is a ratio of litres dispensed per revolution of the meter. To calibrate the dispenser/pump, dispense fuel into a certified measuring container and compare the displayed value with the amount dispensed.

For example:

Displayed volume: 10.00 litres

Measured volume: 20.00 litres

Then, to calculate the correct K-Factor apply the formula below:

$$\begin{aligned} [\text{New K-Factor}] &= [\text{Existing K-Factor}] \times \frac{[\text{Measured volume}]}{[\text{Displayed volume}]} \\ &= [\text{Existing K-Factor}] \times \frac{20.00}{10.00} \\ &= [\text{Existing K-Factor}] \times 2 \end{aligned}$$

Change the existing K-Factor to this new value.

6. Diagnostics

6.1 Error Messages

6.1.1 Fatal Error Codes

The following errors are classified as fatal and require that the system be repowered to be cleared:

Displayed Error Msg.	Fault	Action
Err 11	Excess pulses detected on either pulser channel.	Pulse channel detector may have failed.
Err 12	Excess pulser reverse rotation.	Non-return valve may be faulty.
Err 16	Pulser disconnected.	Check pulser connections.
Err 17	Illegal pulser state or state transition.	Check pulser. Channel may have failed or excess rotation speed may have occurred.
Err 34	Processor Silicon Serial Number device not detected.	SSN IC is damaged or missing. Processor may require replacement.
Err 35	EEPROM data error.	Re-enter configuration data. If error reoccurs replace Processor board.
Err 36	EEPROM totals data error.	Re-power system. If error reoccurs replace Processor board.
Err 38	Flash memory error.	Replace Processor board.
Err 39	EEPROM failure.	EEPROM not responding. Replace processor board.
Err 80	PSU Expansion Card offline.	Check connections to PSU Expansion card.
Err 84	Temperature Probe Interface Card offline.	Check TBus power. Check connections to Temperature IFC.
Err 88	Data message response from Display board not detected.	Check TBus power. Check connections to Display board.
Err 89	Display board not detecting data message from processor.	Check TBus power. Check connections to Display board.

6.1.2 Non-Fatal Error Codes

The following errors are classified as non-fatal and either clear after a short timeout or do not prevent another delivery from starting:

Displayed Error Msg.	Fault	Action
AGain	ID was not correctly read.	Present ID again. If error keeps reoccurring then check the connections to the Reader and replace Reader if necessary.
---x---	ID rejected.	The x in the error message is a code indicating the reason the ID was rejected. Possible reasons are: <ol style="list-style-type: none"> 1. expired ID 2. invalid ID 3. wrong ISO and/or Access No 4. Pre-allocated dollar limit reached. 5. Limit reached 6. ID already in use 7. Expired timer 8. Invalid function code 9. System error
Err 19	The air detect switch has closed during delivery*.	Check for possible sources of air introduction in pumping components.
dEn	LPG density is out of range	If there is a real-time density probe attached, check for faults or check LPG. If using static density parameter, check the value it is set to.
tEP	LPG temperature is out of range	If there is a real-time temp probe attached, check for faults or check LPG. If using a static temp parameter, check the value it is set to.

*Note: The air detection switch is a normally-open pressure activated switch, which closes when the pressure of the air venting from the pumping unit exceeds a preset level. If this switch is detected closed during a delivery then the delivery is stopped. The switch is only monitored once the delivered amount exceeds one litre.

6.1.3 Passive State Indicators

- A colon : character replacing the decimal point in the litres display indicates that the system has been power cycled. It disappears once the first delivery starts or once an ID is presented.
- A triple-colon ⋮ character replacing the decimal point in the litres display indicates that the system has had an internal fault which has reset the T5 processor unexpectedly.

6.2 Fault Finding

Symptom	Actions
Colon appears on litres display without being repowered.	<ul style="list-style-type: none"> • Mains power may be low. • Power cable connection may be faulty. • Processor board may be faulty causing a watchdog reset of the system.
Diagnostic LED 2 not flashing	<ul style="list-style-type: none"> • Is the power on? • Check fuses • Replace processor board
Power LED off	<ul style="list-style-type: none"> • Is the power on? • Check fuses • Replace PSU
Diagnostic LED 2 does not flash fast when a nozzle is lifted.	Check the nozzle switch is connected and adjusted correctly.
Motor won't start or solenoids won't energise.	<ul style="list-style-type: none"> • Are motor/solenoid LEDs on PSU on ? • Check motor and solenoid fuses • Check all motor connections • Check motor • Check wiring • Check connection between Processor and PSU • Check nozzle switch is working